



FLUITECO[®] OPERA **ORGANIC
EXTRACTOR**

PRETREATMENT HOUSE 

YOUR PRETREATMENT HOUSE

OPERA ORGANIC EXTRACTOR

DESIGN & MANUFACTURED BY



OPERA Designed and manufactured to separate the organic fraction from the packages like plastic, metal, styrofoam, or cardboard containers.



OPERA ORGANIC EXTRACTOR

is a combination between shredding principle and forced ventilation.

PATENT PENDING

- ### BENEFITS
- Forced ventilation reduce water consumption for dilution
 - High reliability
 - Generate income from Waste separation
 - High and constant performance
 - Simple & minimal maintenance

INNOVATIVE DESIGN

The separation chamber gives the advantage to recovery the maximum quantity of contaminants obtaining organic fraction very clean with a minimal residual presence of impurities.



HOW IT WORKS

OPERA ORGANIC EXTRACTOR can be loaded with mechanical bucket or with screw or belt conveyor. The waste enters into the **RECEIVAL HOPPER** where the feeding screw that brakes and conveys the waste into the **SEPARATION CHAMBER**. The octagonal fan pushes the organic through the holes of the drum and then to the **ORGANIC OUTPUT**, instead of the contaminants are discharged separately to the **CONTAMINATS OUTPUT**.

FOOD WASTE/FORSU

WASTE SORTING & NOT, PACKEAGED IN METAL, GLASS, PLASTIC STYROFOAM OR CARDBOARD



RECEIVAL HOPPER

SEPARATION CHAMBER

EFFICIENCY AND PERFORMANCES

Capacity from 8 to 20 Tons/hour depending from waste to treat

Organic <0.5% Contamination

Packaging Material more than 65% Dry

Contamination lower than 4%



ORGANIC FRACTIONS EXTRACTED



CONTAMINANTS PACKAGES REMOVED



APPLICATIONS

ANAEROBIC DIGESTION PLANTS for the preparation of the substrate to be sent to the digester

- **COMPOSTING PLANTS** for the preparation of wet to send to mixing with the green
- **RECEIVING STATIONS** and transfer of organic waste to carry out a preliminary treatment of the matrix
- **RECOVERY AND PROCESSING** of **PACKAGED FOODS EXPIRED**
- **WASTE TREATMENT** for cleaning reusable fractions
- **FOOD INDUSTRY** for the recovery of production waste
- **BOTTLING INDUSTRIES** for the reduction of process wastes to be sent to landfill

DIMENSIONS

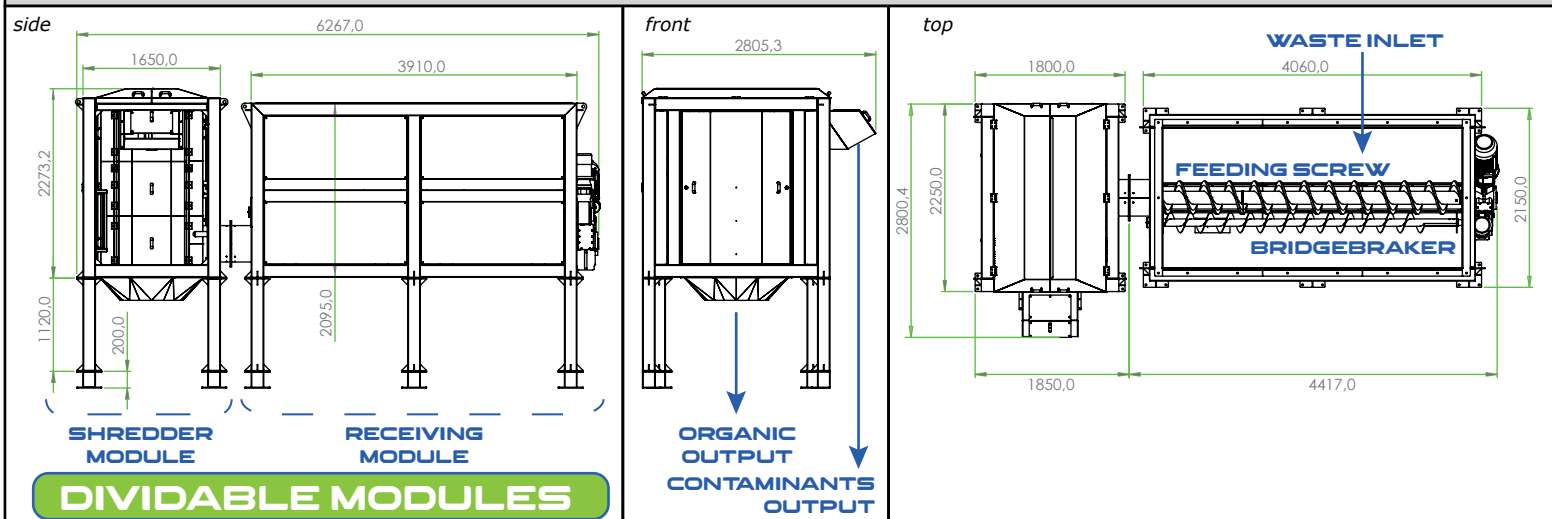

TECHNICAL DATASHEET

CAPACITY

6mc with optional extra 4mc

MOTORISATIONS

55Kw up to 75Kw

DEVICES

Automatic Greaser

CONSTRUCTION MATERIALS

SS304 | SS316 | micro alloy steel painted

OPERA 200 can be supplied with double pre-shredder and feeding conveyors. Shredding conveyors provide to shred partially the waste before to enter into the separation chamber increasing the capacity of the system in term of Tons/h

OPERA MINI available!
Contact Fluiteco for more info

COMPACT SOLUTION



Fluiteco S.r.l. Certified manage system – ISO9001:2015

Strada del lavoro n°183 – 47894 – Chiesanuova, Repubblica di San Marino

Tel. +39 0549.911491 - Web www.fluiteco.com | www.pretreatmenthouse.com