



YOUR PRETREATMENT HOUSE

SDH SLUDGE CLEANER

MANUFACTURED BY
FLUITECO

THE UNIT

Designed to clean industrial and municipal sludge, the SDH is the perfect combination of simple design with high reliability and performance.

Available are two models, SDH200 and 400 for different flows and conditions.



FLUITECO DESIGN 2022

HOW IT WORKS



Primary sludge is pumped passing through a perforated drum, which by a screw that catch and push out the screenings cleans the inlet flow keeping it pressurized. In the last stage of this process is a cone which pneumatically regulates the counter thrust in order to hold the pressure inside the unit.

MODELS OVER THE YEARS



BENEFITS



FLUITECO SDH SLUDGE CLEANER

- HIGH RELIABILITY
- CONTINUOUS SCREENING
- LOW ENERGY CONSUMPTION
- COMPACT & FULLY ENCLOSED DESIGN
- LOW NOISE LEVEL
- INDOOR AND OUTDOOR INSTALLATION
- SIMPLE CONTROL SYSTEM
- HIGH AND CONSTANT PERFORMANCE
- SIMPLE & MINIMAL MAINTENANCE



SLUDGE CLEANING PROCESS

2 by means of a perforated duct the screenings present in the sludge are removed while maintaining the flow under pressure

1 the sludge produced by the process is pumped into the SDH

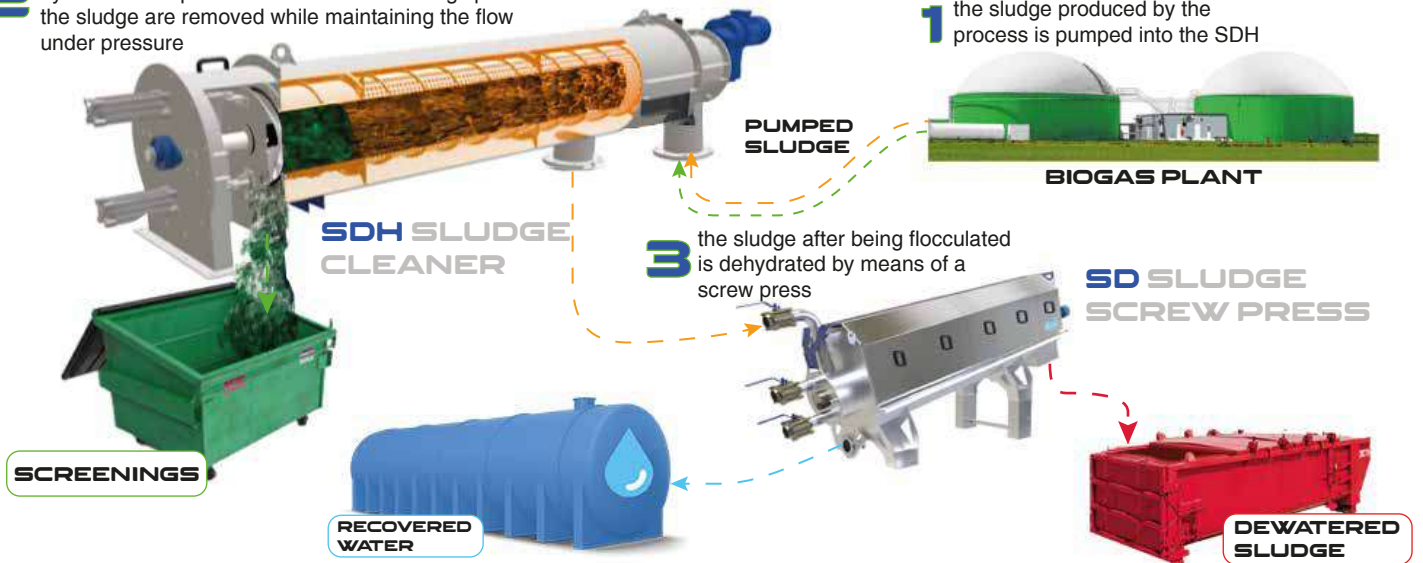

Layouts for illustrative purposes. Different options with also **SDS SLUDGE THICKENER**, **CCS SCREW CONVEYORS** can also be included.

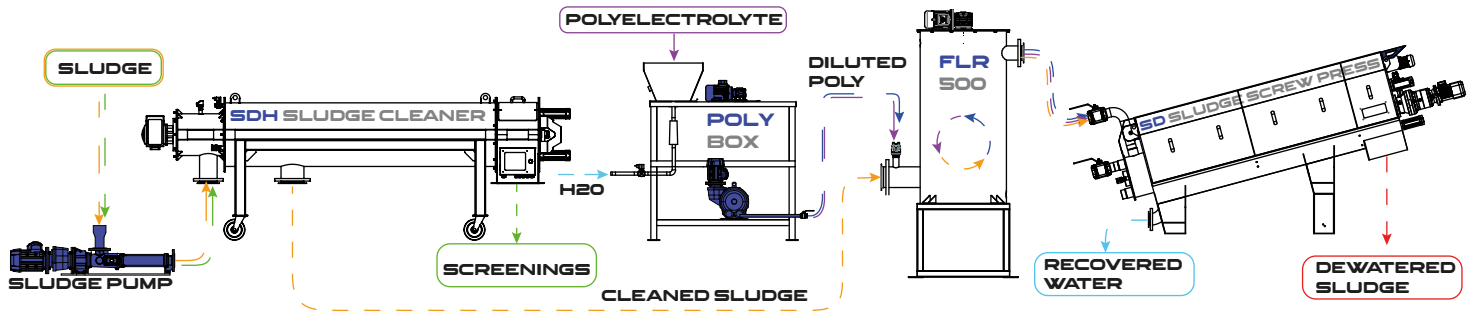

INSTALLATIONS AROUND THE WORLD



SLUDGE CLEANER UNIT

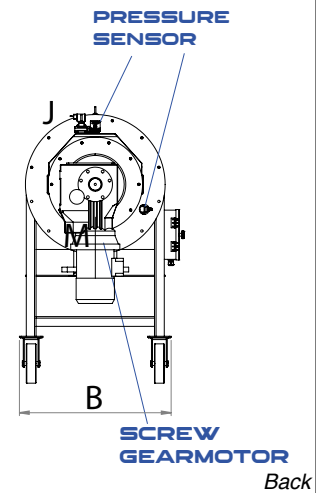
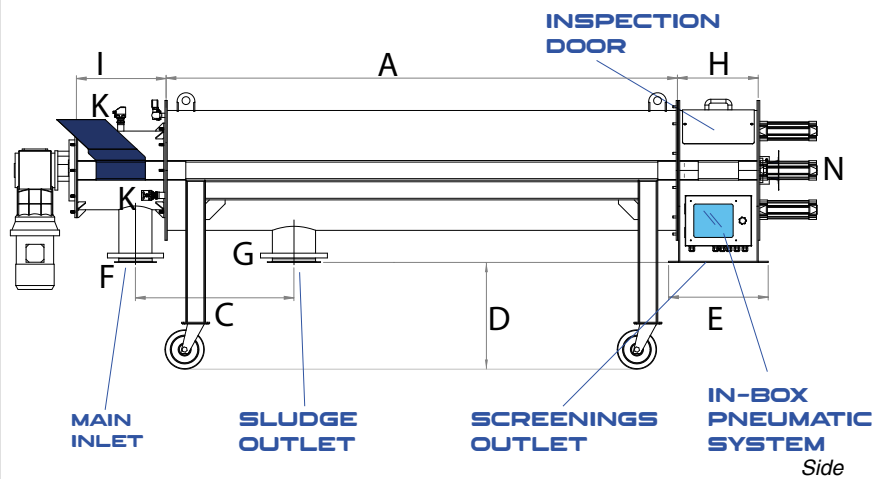
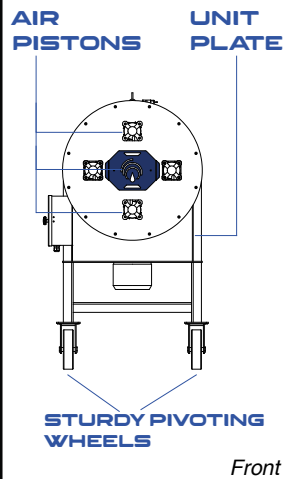

TECHNICAL DATASHEET

Model	SD200	SD400
-------	--------------	--------------

FLOW		
Solids Content	Hydraulic Capacity m3/hr	
<2%	30	90
3-5%	12	30
15%	<i>application defined</i>	
Inlet Pressure	<i>up to 0,6Bar</i>	

FILTRATION		
Perforation holes	<i>application defined</i>	

DIMENSIONS		
A	1600mm	2600mm
B	680mm	780mm
C	806mm	
D	543mm	
E	506mm	
α	Horizontal 0°	

PIPES		
F	DN125mm	DN150
G	DN150mm	DN200
H	411mm	
I	456mm	

MOTORISATIONS & DEVICES		
J	Solenoid valve (Included)	
K	Pressure Sensor (Included)	
M	1,5W	2,2kW
rpm	up to 11	
N	80/160	
Air System	COMPLETE IN-BOX SS (included)	
Air l/s	2-4l/s	
Inspection	Bolted - Window Optional (not included)	

MATERIALS

Manufactured in SS304 or 316
Painted iron screw option

